



For all enquiries, spare parts and accessories, contact:



oem group of companies

OEM Group Ltd. London Business Innovation Centre, Mollison Avenue, Enfield, EN3 7XU, United Kingdom.
Tel: +44 (0)20 8344 8777, Fax: +44 (0)20 8344 8778, email: oem@secureseal.com web: www.secureseal.com

OEM Group, PO Box 86, St Stephen, New Brunswick, E3L 2W9, Canada. Tel: 506 466 2205, email: oemcg@aol.com www.secureseal.com

Installation & Operation Instructions



**The Security Seal Testing Authority
(SSTA)**

Certify that the

OEM SECURESEAL

*has been tested in accordance with the security seal's
specification under European Community Regulation 245/93
Article 386, Annex 46A*

and accepted as a sealing device by

**HM CUSTOMS & EXCISE
under
GROUP 1**

*The commissioners reserve the right to withdraw
acceptance at any time, this seal is acceptable
to H M Customs and Excise until it requires a retest*

on

25th February 2007

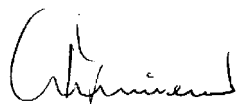
 25th Feb 2007

Signed and dated on behalf of Security Testing Authority

Installation and Operating Instructions for :

*Secureseal, Secureloc
Secureseal/Secureloc.VMS
Secureseal/Secureloc.DATA
Secureseal.DOCK (Demountable)
Secureseal.Hinged (Option)*

Contents

1. Introduction	page 4
<i>Seal types</i>	
<i>How to use these Instructions</i>	
2. Positioning the Seal -Standard & Looped Cable Assemblies	
<i>Todco/Henderson type</i>	page 5
<i>Whiting lever type</i>	page 6
<i>Swing out type</i>	page 7
3. Positioning the Seal - Multiple Cable Assemblies	page 7
4. Installing the Seal - Secureseal/Secureloc	page 8
5. Installing the Seal - Secureseal/Secureloc.VMS	page 9/10
6. Installing the Seal - Secureseal/Secureloc.DATA	page 10
<i>Replacing the Battery</i>	page 11/12
7. Installing the Seal - Secureseal.DOCK	page 12
<i>Special Positioning Instructions</i>	page 13
<i>Fitting the Seal</i>	page 14
<i>Removing the Seal</i>	page 15
8. Operating the Seal	page 15
<i>8a Secureseal</i>	
<i>8b Secureloc</i>	
9. The Cable Assembly	page 16
<i>To install a looped end cable</i>	
<i>To change to multi-cable application</i>	
10. Retro Conversion to 'Hinged' type	page 17
11. Spares and Accessories	page 18
12. Mounting Template	page 19

1. Introduction

Seal Types

These instructions describe the correct positioning and installation of the Secureseal and Secureloc units, plus their VMS and DATA versions and the demountable Secureseal.DOCK. The retrospective conversion of standard Secureseal and Secureloc seals to 'Hinge' type is also described.



Standard Secureseal
(S-010-000-000)



How to use the Instructions

Positioning instructions are common to all models, with additional instructions for the Secureseal.DOCK and Hinged Option. Separate installation instructions are provided for each Secureseal model and apply to both Secureseal and Secureloc variants. It is important to establish which type of seal you are installing and refer to the appropriate section of the instructions. *It is especially important not to confuse Secureseal.DOCK and Secureloc versions.* Please be aware that *all* versions carry the words Secureseal.DATA

2. Positioning the Seal - Standard & Looped Cable assemblies

(for Cable change instructions, refer to Section 9)

Todco/Henderson type Lock Mechanism

With the Seal Unit open (see Section 8):

2.1a Standard Cable

thread the free end of the cable assembly through the lock catch, as shown in diagram (a)

2.1b Looped Cable

thread the stop-end of the looped cable through the lock catch and then through the loop at the other end of the cable, as shown in diagram (b)

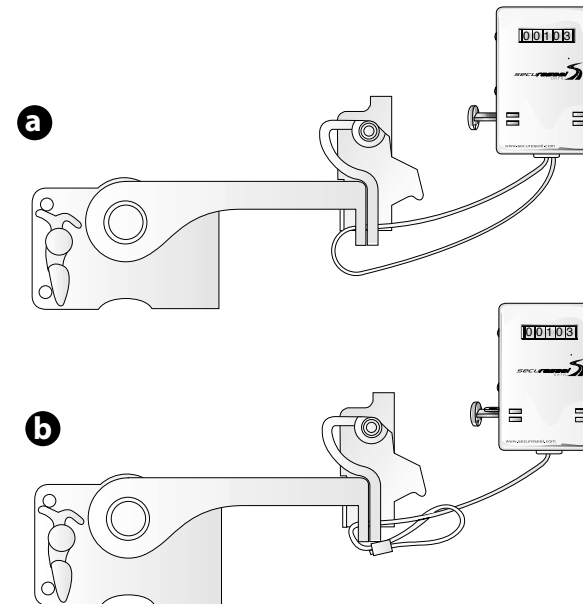

2.2. Insert the free stop-end of the cable into the plunger and close the seal by pushing the plunger up into the seal unit body until it clicks.

2.3. Move the seal unit within the selected door area so that the cable is tight enough to prevent the door catch being moved enough for the handle to be opened. *Make sure that the seal unit cannot interfere with the proper operation of the lock mechanism or the opening of the door.*

2.4. Mark the position of the seal unit on the door.*

* Special additional instructions apply to Secureseal.DOCK
Refer to Section 7

2. Positioning the Seal -Continued

Whiting lever-type Lock Mechanism

With the Seal Unit open (see Section 8):

2.5a Standard Cable

thread the free end of the cable assembly through the handle locking slot/hole, as shown in diagram (c)

2.5b Looped Cable

thread the stop-end of the looped cable through the handle locking slot/hole and then through the loop at the other end of the cable, as shown in diagram (d)

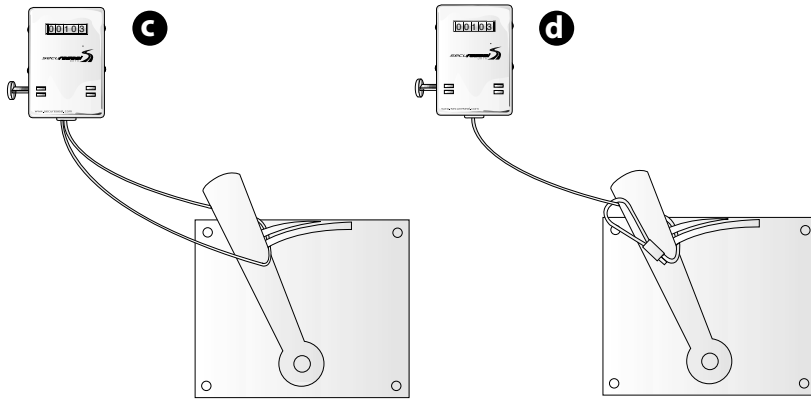

2.6. Insert the free stop-end of the cable into the plunger and close the seal by pushing the plunger up into the seal unit body until it clicks.

2.7. Move the seal unit within the selected door area so that the cable is tight enough to prevent the handle being moved enough to open the latch. *Make sure that the seal unit cannot interfere with the proper operation of the latch mechanism or the opening of the door.*

2.8. Mark the position of the seal unit on the door.*

* **Special additional instructions apply to Secureseal.DOCK**
Refer to Section 7

2. Positioning the Seal -Continued

Swing-out type (Barn) door

With the Seal Unit open (see Section 8):

2.9a Standard Cable

thread the free end of the standard cable through the lock catch as shown in diagram (e)

2.9b Looped Cable

thread the stop-end of the looped cable through the lock catch and then through the loop at the other end of the cable, as shown in diagram (f)

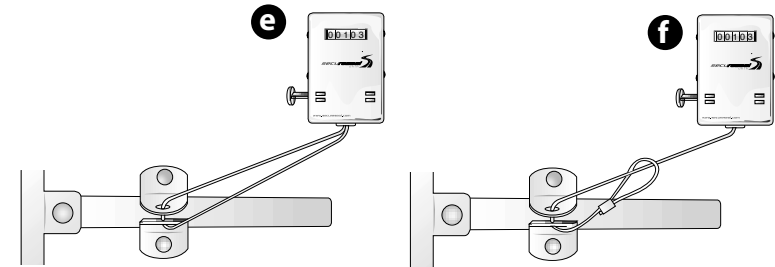

2.10. Insert the free stop-end of the cable into the plunger and close the seal by pushing the plunger up into the seal unit body until it clicks.

2.11. Move the seal unit within the selected door area so that the cable is tight enough to prevent the door catch being moved enough to allow the door to be opened. *Make sure that the seal unit cannot interfere with the proper operation of the door catch, or the opening of the door.*

2.12. Mark the position of the seal unit on the door.*

* **Special additional instructions apply to Secureseal.DOCK**
Refer to Section 7

3. Multiple Cable Assemblies

Where it is intended to use multiple cables, e.g. curtain-sided trailers, tanker access covers and discharge valves, it is recommended that the seal unit is mounted in a convenient practical location and the cables tailored to fit. Custom-made cables are available from **OEM Group Limited**. Refer to Section 9 for Cable change instructions.

4. Installing the Seal - *Secureseal, Secureloc*

Components

- | | |
|----------------------|------------------------------------|
| 1. Seal Unit Body | 6. Spring Washer (x4) |
| 2. Rubber Gasket | 7. Nut (x4) |
| 3. Fabric Dust Cover | 8. Plastic Nut Cover (x4) |
| 4. Threaded Rod (x4) | 9. Roll Pin Part No 'ROLL PIN' |
| 5. Flat Washer (x4) | 10. Standard Cable - 750mm (29.5") |

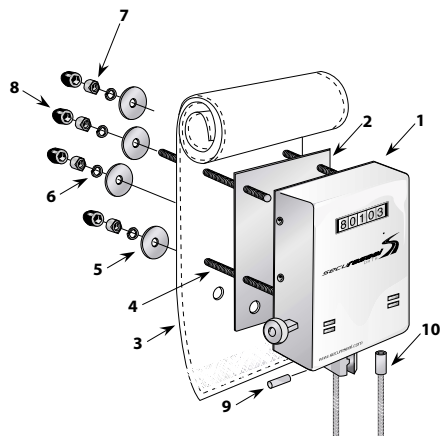

Secureseal shown; Secureloc component and installation identical

4.1. Using the template printed on page 19, place it in the marked position on the door. Mark the position of the four holes 'A'.

4.2. Remove the template and drill four 7mm (9/32") diameter holes through the door. Ensure that the holes are drilled at 90° to avoid difficulty inserting the Threaded Rods.

4.3. Screw the four Threaded Rods (4) into the holes in the back-plate of the Seal Unit Body (1) and tighten. *Do not exceed 5N/m (4ft/lbs) torque*

4.4. Fit the Rubber Gasket (2) over the Threaded Rods.

4.5. Fit the Fabric Dust Cover (3) over the Threaded Rods so that the Velcro fastening faces the Seal Unit and the longest part extends above the Seal Unit body.

4.6. With the plunger of the Seal Unit at the bottom and the Fabric Cover draped forward over the Seal, insert the Threaded Rods through the holes drilled in the door.

4.7. On the inside of the door, fit a Flat Washer (5) onto each Threaded Rod, followed by a Spring Washer (6).

4.8. Screw a Nut (7) onto each Threaded Rod. Tighten down evenly to pull the Seal Unit firmly against the exterior of the door. *Do not exceed 5N/m (4ft/lbs) torque*

4.9. Cut off excess Threaded Rod and fit a Plastic Nut Cover (8) over each nut.

5. Installing the Seal - *Secureseal, Secureloc. VMS*

These units are supplied fitted with a microswitch and with a Data Pack cover only, plus longer fixing rods. This permits easy upgrade to Secureseal.DATA and it is recommended that the seal is installed as described below.

Components

- | | |
|-----------------------|------------------------------------|
| 1. Seal Unit Body | 7. Nut (x4) |
| 2. Rubber Gasket | 8. Plastic Nut Cover (x4) |
| 3. Fabric Dust Cover | 9. Roll Pin Part No 'ROLL PIN' |
| 4. Threaded Rod (x4) | 10. Standard Cable - 750mm (29.5") |
| 5. not applicable | 11. Data Pack Cover |
| 6. Spring Washer (x4) | 12. Microswitch Wires |

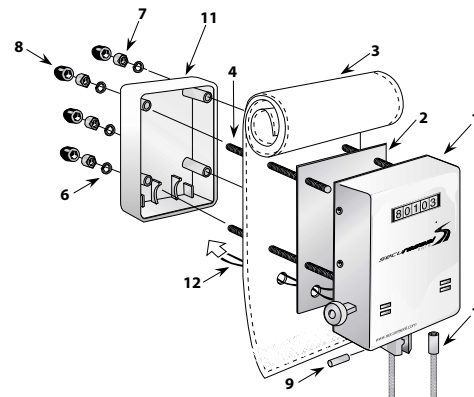

Secureseal shown; Secureloc component and installation identical

5.1. Using the template printed on page 19, place it in the marked position on the door so that the fifth, larger hole is at bottom left. Mark the position of the five holes (4 x A + 1 x B).

5.2. Remove the template and drill four 7mm (9/32") holes and the fifth 8mm (5/16") hole through the door. Ensure that the 7mm holes are drilled at 90° or the Threaded Rods may not align properly on the inside to accept the Data Pack Cover.

5.3. Screw the four Threaded Rods (4) into the holes in the back-plate of the Seal Unit Body (1) and tighten. *Do not exceed 5N/m (4ft/lbs) torque.*

5.4. Fit the Rubber Gasket (2) over the Threaded Rods and pass the Microswitch Wires (12) through the fifth hole.

5.5. Fit the Fabric Dust Cover (3) over the Threaded Rods so that the Velcro fastening faces the Seal Unit and the longest part extends above the Seal Unit body. Pass the Microswitch Wires (12) through the fifth hole.

5.6. With the plunger of the Seal Unit at the bottom and the Fabric Cover draped forward over the Seal, thread the Microswitch wires through the lower, largest hole in the door and insert the Threaded Rods through the other four holes.

5. Installing the Seal - *Secureseal, Secureloc.VMS*

Continued

5.7. On the inside of the door, fit the Data Pack Cover (11) onto the Threaded Rods so that the internal battery profiles are at bottom and the logo is the correct way up. Stow the Microswitch wires inside the Cover, making sure they are not trapped.

5.8. Fit a Spring Washer (6) onto each Threaded Rod.

5.9. Screw a Nut (7) onto each Threaded Rod. Tighten down evenly to pull the Seal Unit and the Data Pack Cover firmly against the surfaces of the door. *Do not exceed 5N/m (4ft/lbs) torque.*

5.10. Cut off excess Threaded Rod and clean up the ends with a fine file. Fit a Plastic Nut Cover (8) over each nut.

6. Installing the Seal - *Secureseal, Secureloc.DATA*

Components

- | | |
|----------------------------------|---|
| 1. Seal Unit Body | 9. Roll Pin Part No 'ROLL PIN' |
| 2. Rubber Gasket | 10. Standard Cable - 750mm (29.5") |
| 3. Fabric Dust Cover | 11. Data Pack Cover |
| 4. Threaded Rod (x4) | 12. Microswitch Wires |
| 5. not applicable | 13. Microswitch/Data Pack Connector (x2) Part No M4450 |
| 6. Spring Washer (x4) | 14. Battery Part No 00741A |
| 7. Nut (x4) | 15. Data Pack |
| 8. Plastic Nut Cover (x4) | |

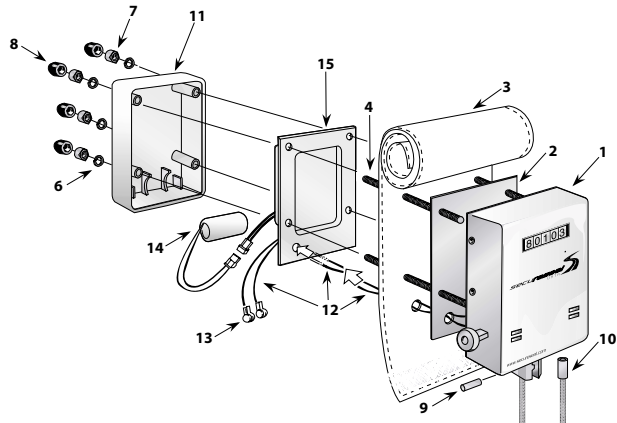

Secureseal shown; Secureloc components and installation identical

6.1. Using the template printed on page 19, place it in the marked position on the door so that the fifth, larger hole is at bottom left. Mark the position of the five holes (4 x **A** + 1 x **B**).

6.2. Remove the template and drill four 7mm (9/32") holes and the fifth 8mm (5/16") hole through the door. Ensure that the 7mm holes are drilled at 90° or the Threaded Rods may not align properly on the inside to accept the Data Pack and Cover.

6. Continued

6.3. Screw the four Threaded Rods (4) into the holes in the back-plate of the Seal Unit Body (1) and tighten. *Do not exceed 5N/m (4ft/lbs) torque.*

6.4. Fit the Rubber Gasket (2) over the Threaded Rods and pass the Microswitch wires (12) through the fifth hole.

6.5. Fit the Fabric Dust Cover (3) over the Threaded Rods so that the Velcro fastening faces the Seal Unit and the longest part extends above the Seal Unit body. Pass the Microswitch wires through the fifth hole.

6.6. With the plunger of the Seal Unit at the bottom and the Fabric Cover draped forward over the Seal, thread the Microswitch wires through the lower, largest hole in the door and insert the Threaded Rods through the other four holes.

6.7. On the inside of the door, fit the Data Pack (15) over the Threaded Rods so that the flat side is towards the door and the larger hole is at bottom right. Pass the Microswitch wires through this hole.

6.8. The two un-terminated wires from the Data Pack connect to the wires from the Microswitch, using the Connectors (13). Push both BROWN wires fully home into one Connector and both GREY wires into the other. **DO NOT STRIP INSULATION FROM THE WIRES!**

Use pliers to squeeze the Orange cap of each Connector into its clear nylon body. A small amount of silicone grease may leak out. This is normal.

NOTE: Some Seal Units may have BLUE and BLACK wires. In this case, connect BLUE to BROWN and BLACK to GREY.

6.9. Plug the Battery (14) into the nylon socket of the Data Pack. The plug and socket only fit together one way - RED to RED / BLACK to BLACK.

6.10. Fit the Data Pack Cover (11) onto the Threaded Rods so that the internal battery profiles are at bottom and the logo is the correct way up. Position the Battery in the profiles and make sure no wires are trapped. Push the Cover home against the Data Pack.

6.11. Fit a Spring Washer (6) onto each Threaded Rod.

6.12. Screw a Nut (7) onto each Threaded Rod. Tighten down evenly to pull the Seal Unit and the Data Pack and Cover firmly together against the door. *Do not exceed 5N/m (4ft/lbs) torque.*

6.13. Cut off excess Threaded Rod and clean up the ends with a fine file. Fit a Plastic Nut Cover (8) over each Nut.

Replacing the Battery

The Battery has a working life of two to four years, depending upon frequency of seal status change. The Data Pack will indicate when the battery requires replacement and this will be displayed on the user's base computer.

6. Installing the Seal - *Secureseal, Secureloc.DATA*

Continued - Replacing the Battery

- 6.14.** To replace the Battery, remove the four Plastic Nut Covers (8), the Nuts (7) and the Spring Washers (6).
- 6.15.** Carefully pull the Data Pack Cover (11) from the Threaded Rods. Unplug and discard the old Battery. *(The Battery is Lithium type and should be disposed of in accordance with statutory requirements)*
- 6.16.** Fit the new Battery (Part No. 00741A) and re-assemble the Data Pack as described in steps 6.9 - 6.13 above.

Checking Data Pack Function

Following initial installation or Battery replacement, proper function of the Data Pack should be confirmed. To accomplish this it is necessary to have a suitable receiver linked to a computer running appropriate software.

7. Installing the Seal - *Secureseal.DOCK*

Components

- | | |
|--|------------------------------------|
| 1. Seal Unit Body (fabric cover attached)* | 11. not applicable |
| 2. not applicable | 12. not applicable |
| 3. not applicable | 13. not applicable |
| 4. not applicable | 14. not applicable |
| 5. Flat Washer (x3) | 15. not applicable |
| 6. Spring Washer (x3) | 16. Key (x2) |
| 7. Nut (x3) | 17. M6 Cup Square Bolts (x3) |
| 8. Plastic Nut Cover (x3) | 18. Auxiliary Back Plate (fixed) |
| 9. Roll Pin Part No 'ROLL PIN' | 19. Stainless Steel Mounting Plate |
| 10. Standard Cable - 750mm (29.5") | |

* for clarity, the fabric cover is shown in broken line

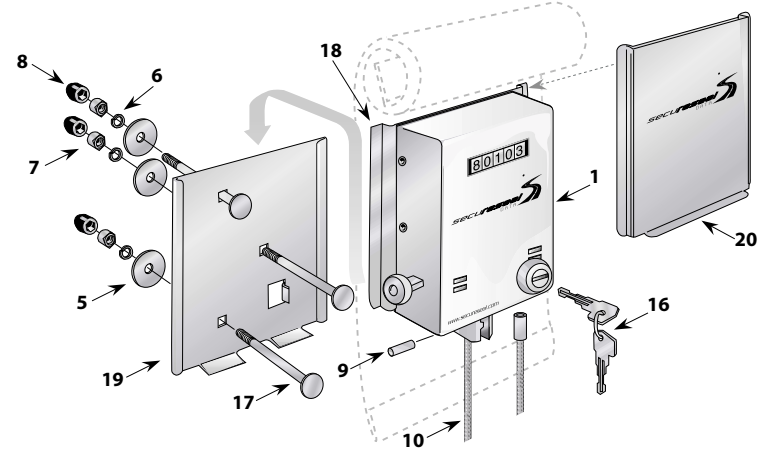

NOTE: KEY MUST BE ENGAGED TO ENABLE SEAL TO BE PLACED INTO MOUNTING PLATE

7.1. Special Instructions for Positioning

Secureseal.DOCK

Before attempting to position the Seal on the door, it must be mounted onto the Stainless Steel Mounting Plate (19) The unit is normally supplied in this condition but, should it have been removed, replace it as follows:

- 7.1.1.** Insert the key (16) into the lock (it will only go in one way - with the smooth side uppermost) and turn it anti-clockwise through 90°.
- 7.1.2.** Engage the edges of the Seal Unit Auxiliary Back Plate (18) in the side channels of the Mounting Plate (19) and slide the Unit down until it locates against the two lugs at the bottom of the Mounting Plate.

CAUTION

To avoid damaging the locking cam, the key must be held firmly in the full anti-clockwise position.



- 7.1.3.** Turn the key back clockwise to secure the Seal to the Mounting Plate.
- 7.1.4.** Establish the position of the Seal Unit as described in Section 2.
- 7.1.5.** Hold the Seal Unit in position, lift the fabric cover clear and mark the position of the Mounting Plate (19). It is sufficient to mark two diagonally opposed corners.



7.2. Installing the Seal

Secureseal.DOCK

7.2.1. Remove the Seal Unit from the Mounting Plate by turning the key anti-clockwise through 90° and sliding the Unit up from the Mounting Plate. *Hold the key firmly in the anti-clockwise position to allow the cam gate to pass over the Mounting Plate locking lug.*

7.2.2. Position the Mounting Plate to the markings on the door. Mark the position of the three square holes.

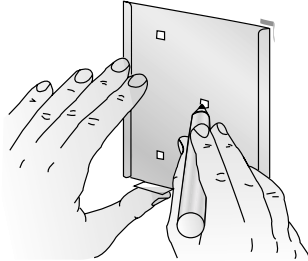

7.2.3. Remove the Mounting Plate and drill three 7mm (9/32") holes through the door.

7.2.4. Offer up the Mounting Plate and insert the three M6 Cup Square Bolts (17), making sure that the square sections locate properly into the square holes.

7.2.5. On the inside of the door, fit a Flat Washer (5), Spring Washer (6) and Nut (7) to each bolt. Tighten lightly. Check again the location of the square bolt sections in the square holes then tighten down so that the Mounting Plate is pulled firmly against the door surface. *Do not exceed 5N/m (4ft/lbs)*

7.2.6. Check that the Mounting Plate is not distorted, then cut off excess bolt close to each nut and push on a Plastic Nut Cover (8).

7.2.7. Fitting the Secureseal.DOCK after installation.

If the key has been removed from the lock, re-insert it (smooth side uppermost) Holding the fabric cover clear, insert the Auxiliary Back Plate (18) of the Seal Unit into the top of the Mounting Plate (19), engaging the edges in the side channels. Turn the key anti-clockwise through 90° and push the Seal Unit down firmly until it locates against the two lugs at the bottom of the Mounting Plate *Hold the key firmly in the anti-clockwise position to allow the cam gate to pass freely over the Mounting Plate locking lug.*

7.2.8. Turn the key clockwise through 90° and remove it from the lock. Check that the Seal Unit cannot be removed from the Mounting Plate.

7.2.9. Removing Secureseal.DOCK

Make sure that the cable is detached from the door latch mechanism. Insert the key in the lock (smooth side uppermost) and turn it anti-clockwise through 90° *Hold it firmly in this position and slide the Seal Unit up and out of the Mounting Plate.* If the Seal Unit is to be removed for an extended period, fit the Mounting Plate Cover (20) to protect the Mounting Plate.

8. Operating the Seal

8a Operating Secureseal

8a.1. Open the Seal by pulling out the Slide at the lower left side of the Seal Unit Body. This action will extend the Plunger from the underside of the Seal and scramble the 5-digit number of the display to an unreadable condition.

8a.2. Thread the free end of the cable through the door latch mechanism (Standard Cable) or thread the stop-end of the cable through the door latch mechanism and then through the cable loop (Loop Cable) [Refer to Section 2]

8a.3. Insert the cable stop-end into the Plunger and push the Plunger up into the Seal Unit Body until it clicks. This action will retract the opening Slide and generate a new random number in the 5-digit display. Note this number on the load manifest. The cable cannot now be released to allow the door latch to be opened without extending the Plunger and scrambling the 5-digit number again.

8b Operating Secureloc

8b.1. Open the Seal by inserting the key into the lock at the lower right front of the Seal Unit Body. The key will only go in one way - smooth side up. Turn the key anti-clockwise through a full 90°. This action will extend the Plunger from the underside of the Seal and scramble the 5-digit number of the display to an unreadable condition. Remove the key.

8b.2. Thread the free end of the cable through the door latch mechanism (Standard Cable) or thread the stop-end of the cable through the door latch mechanism and then through the cable loop (Loop Cable) [Refer to Section 2]

8b.3. Insert the cable stop-end into the Plunger and push the Plunger up into the Seal Unit Body until it clicks. This action locks the Seal Unit and generates a new random number in the 5-digit display. Note this number on the load manifest. It is not necessary to use the key to lock the Seal. The cable cannot now be released to allow the door latch to be opened without using the key to extend the Plunger and scramble the 5-digit number again.

9. The Cable Assembly

All versions of Secureseal and Secureloc are supplied with the standard 750mm (29.5") cable already installed. This cable has a stop-end swaged on to each end. One stop-end is permanently held in the seal plunger by a roll-pin. This standard cable may be replaced by a looped-end cable or multiple cables.

To install a looped-end cable

1. Open the seal (see Section 8)
2. Drive out the roll-pin and remove the standard cable.
3. Re-fit the roll-pin, making sure that it does not protrude from the plunger sides.

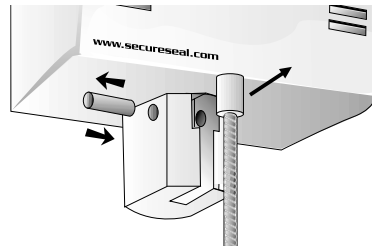

To change to multiple cable application

1. Open the seal (see Section 8)
 2. Drive out the roll-pin and remove the standard cable. Discard the roll-pin.
- With the roll-pin removed, two cable ends (e.g. TIR cables) can be secured by the plunger.

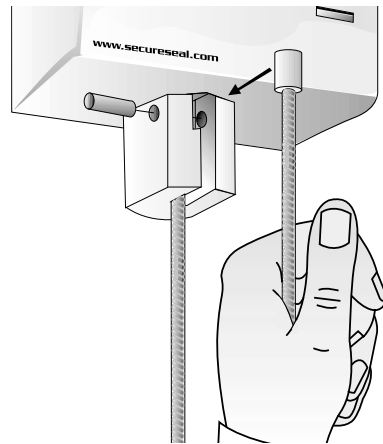

10. Hinge Bracket Conversion

Secureseal/Secureloc

Components

- | | |
|--|----------------------------|
| 1. Existing Seal Unit Body | 6. M6 Cup Square Bolt (x4) |
| 2. Hinge Unit (Carrier Plate 2a & Mounting Plate 2b) | 7. Flat Washer (x4) |
| 3. Button-head hex-socket Tamper-proof Screw with Spring Washer (x4) | 8. Spring Washer (x4) |
| 4. Rubber Gasket | 9. Nut (x4) |
| 5. not applicable | 10. Plastic Nut Cover (x4) |
| | 11. Special Allen Key |

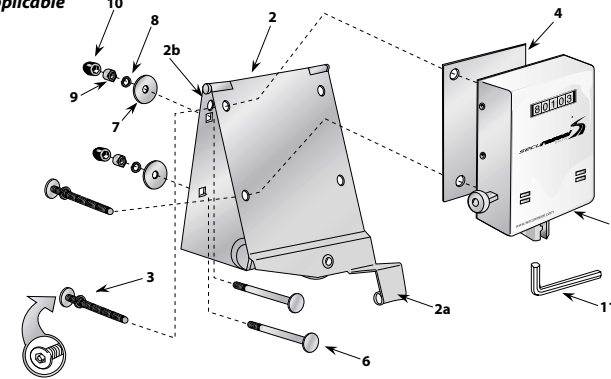

10.1. On the inside of the cargo door: Pull off and discard the Plastic Nut Covers from the four Threaded Rods. Unfasten, remove and discard the Nuts, Spring Washers and Flat Washers.

10.2. Pull the Seal Unit Body (1) from the door. Remove and discard the Fabric Dust Cover and the Rubber Gasket.

10.3. Unscrew and discard the four Threaded Rods from the Seal Unit Body.

10.4. Open the Hinge Unit (2) and, from the inner face of the Seal Unit Carrier Plate (2a) (with bentform handle), thread the four Tamper-proof Screws with spring washers (3) through the **round** holes. Close the Hinge Unit to retain the screws.

10.5. Fit the new Fabric Dust Cover (5) over the Tamper-proof Screws (3) so that the Velcro fastening faces away from the Hinge Unit and the longest part extends above the hinge. (If the Dust Cover has 8 holes, use the lowest group of four).

10.6. Fit the new Rubber Gasket (4) over the Tamper-proof Screws.

10.7. With the Seal Unit Body laid on its side or face, open the Hinge Unit and engage the Tamper-proof Screws into the Seal Unit back-plate. Use the Special Allen Key (11) to screw them down evenly, making sure that the Dust Cover and Rubber Gasket remain flat. Tighten all four screws to 5N/m (4ft/lbs) torque.

10.8. Keeping the Hinge Unit open, offer up the Mounting Plate (2b) (with square holes) to the cargo door and insert the four M6 Cup Square Bolts (6) through the plate and through the existing holes in the door, making sure that the square sections locate properly into the square holes.

10.9. On the inside of the door, fit a Flat Washer (7), Spring Washer (8) and Nut (9) to each bolt. Tighten lightly. Check again the location of the square bolt sections in the square holes then tighten down so that the Mounting Plate is pulled firmly against the door surface. Do not exceed 5N/m (4ft/lbs)

11.0. Check that the Mounting Plate is not distorted, then cut off excess bolt close to each nut and push on a Plastic Nut Cover (10). Make sure that the whole assembly is secure, that the Seal Unit swings up freely and is held firmly by the magnet when lowered to the operating position.

11. Spares and Accessories

1. Standard Cable

750mm Stainless Steel Fixing Cable: Part No.M4280750



2. High Security Cable

750mm Stainless Steel Fixing Cable: Part No.M4280750 SSS-GHD



* **Contact us for special cable length requirements**

3. Hinge Bracket Assembly : Part Name. Hinge-Kit

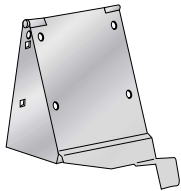

4. Secureseal Dock Mounting Plate : Part No.M4542

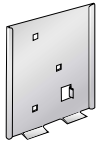

5. Secureseal Dock Cover Plate : Part No.M4551



For further information, spare parts and accessories contact :

OEM Group

Tel: +44 (0) 208 344 8777 Fax: +44 (0) 208 344 8778 email: oem@secureseal.com

12. The Fixing Hole Template

For Secureseal/Secureloc, drill four 7mm (9/32") holes through the door panel at points **A** For VMS and DATA versions, drill an additional 8mm (5/16") hole at point **B**
This template **does not** apply to Secureseal.DOCK.

